



Mechanisms and Strategies to Manage Temperature Stratification in Brewery Vessels

Travis Audet
Anheuser-Busch Inbev



UNITED WE BREW™

Brewing Vessel Cooling

- Applications:
 - Fermentor cooling during fermentation
 - Easy!
 - But beware cooling early in fermentation!
 - Unitank/Fermentor crash cooling
 - Initially easy!
 - As we approach 32F/0C stratification can occur
 - Ageing Tank or Bright Beer Tank cooling
 - Can be tricky with temperature stratification occurring



Brewing Vessel Stratification Mechanism

- As liquid cools it becomes more dense
- As water approaches 4.0C/39.2F it reaches the **Temperature of Maximum Density (TMD)** which is the critical point for the start of temperature stratification
 - As the temperature continues to lower below TMD then the liquid becomes less dense and begins to rise
 - The closer we are to the freezing temperature of the liquid while the surrounding liquid is still at TMD then the greater the stratification energy
- Beer can have differing amounts of alcohol and dissolved solids that can change the TMD and freezing point

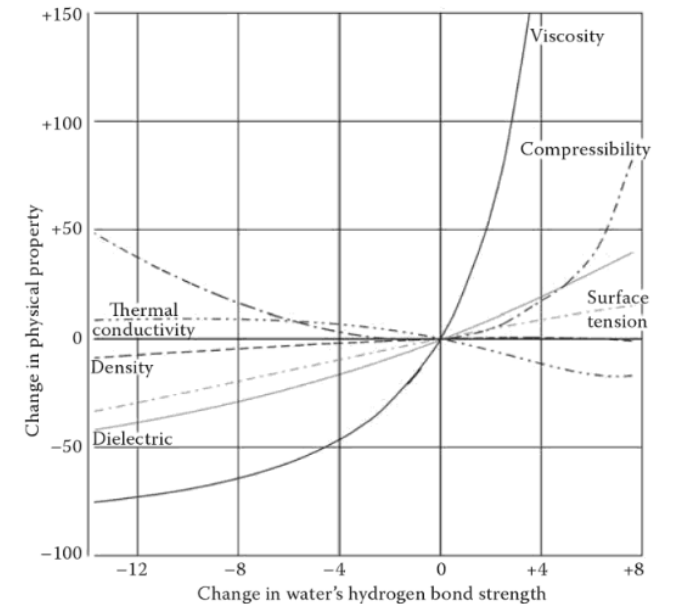
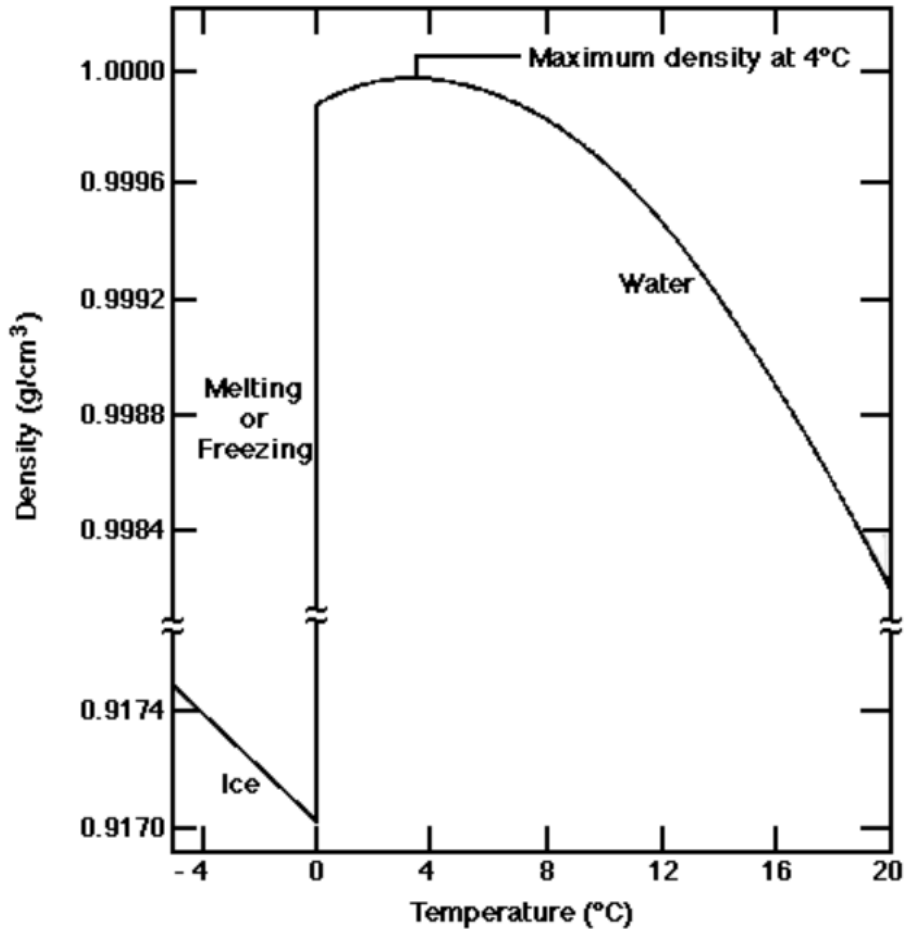

FIGURE 5.2 Variation of water's physical properties with changes in its hydrogen bond strength.



Brewing Vessel Stratification Mechanism



Density of water (and ice) as a function of temperature. Note maximum density of water at 4 °C. (Data from Pauling 1953 and Hutchinson 1957: 204.)

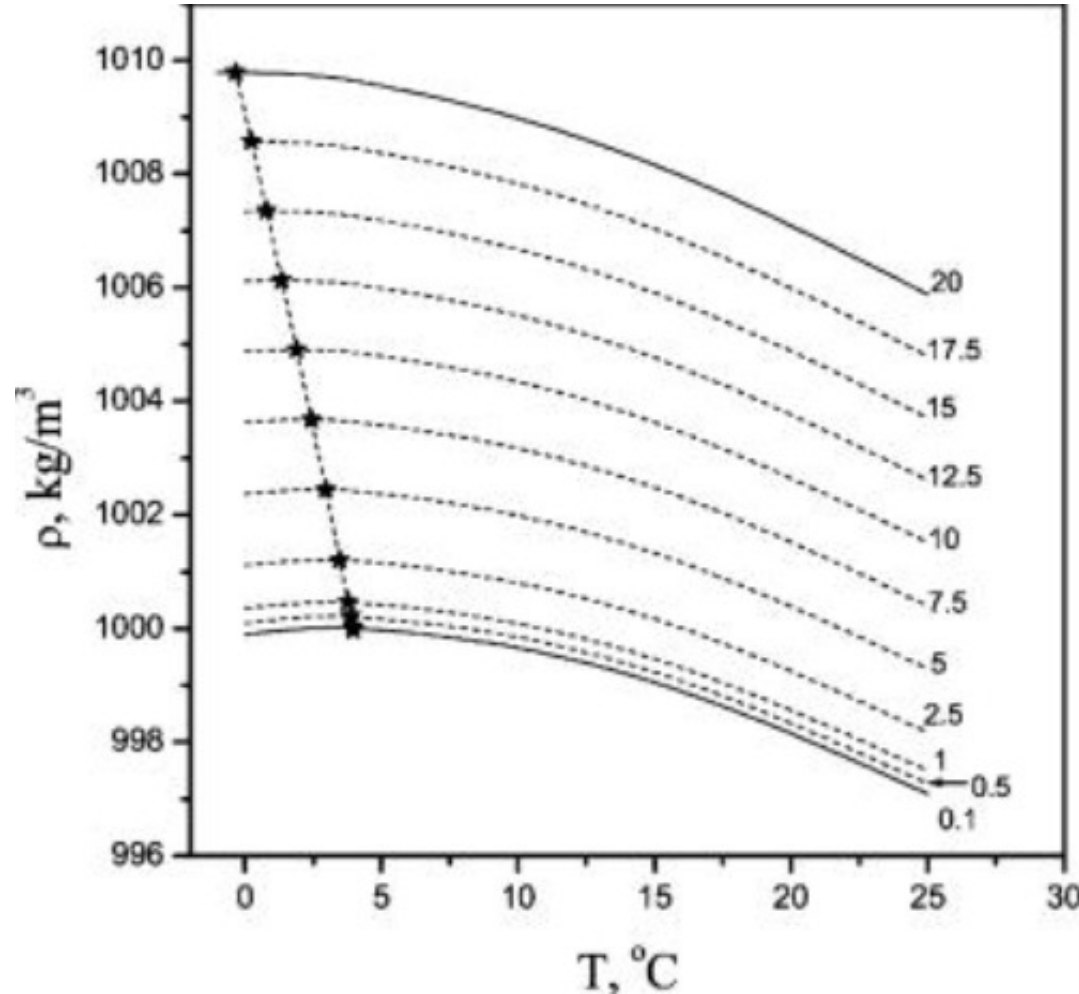

Brewing Vessel Stratification Mechanism

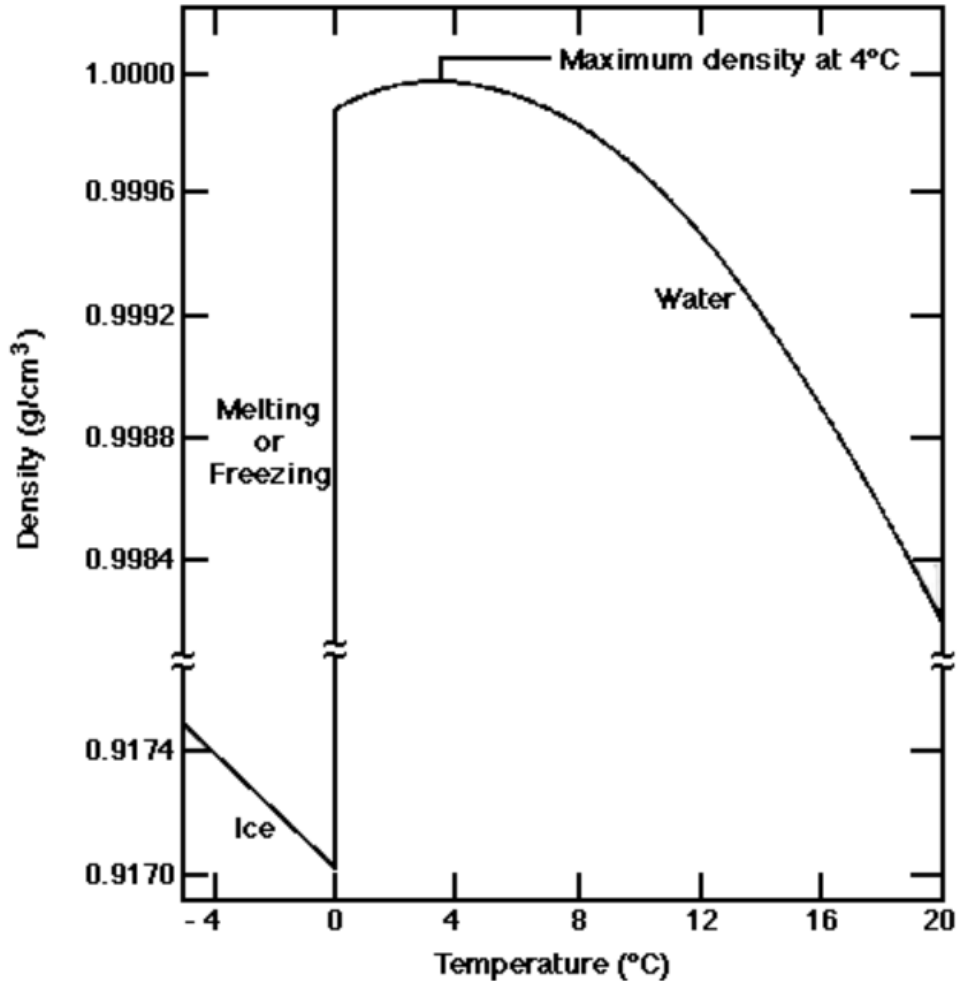

Density of water (and ice) as a function of temperature. Note maximum density of water at 4 °C. (Data from Pauling 1953 and Hutchinson 1957: 204.)

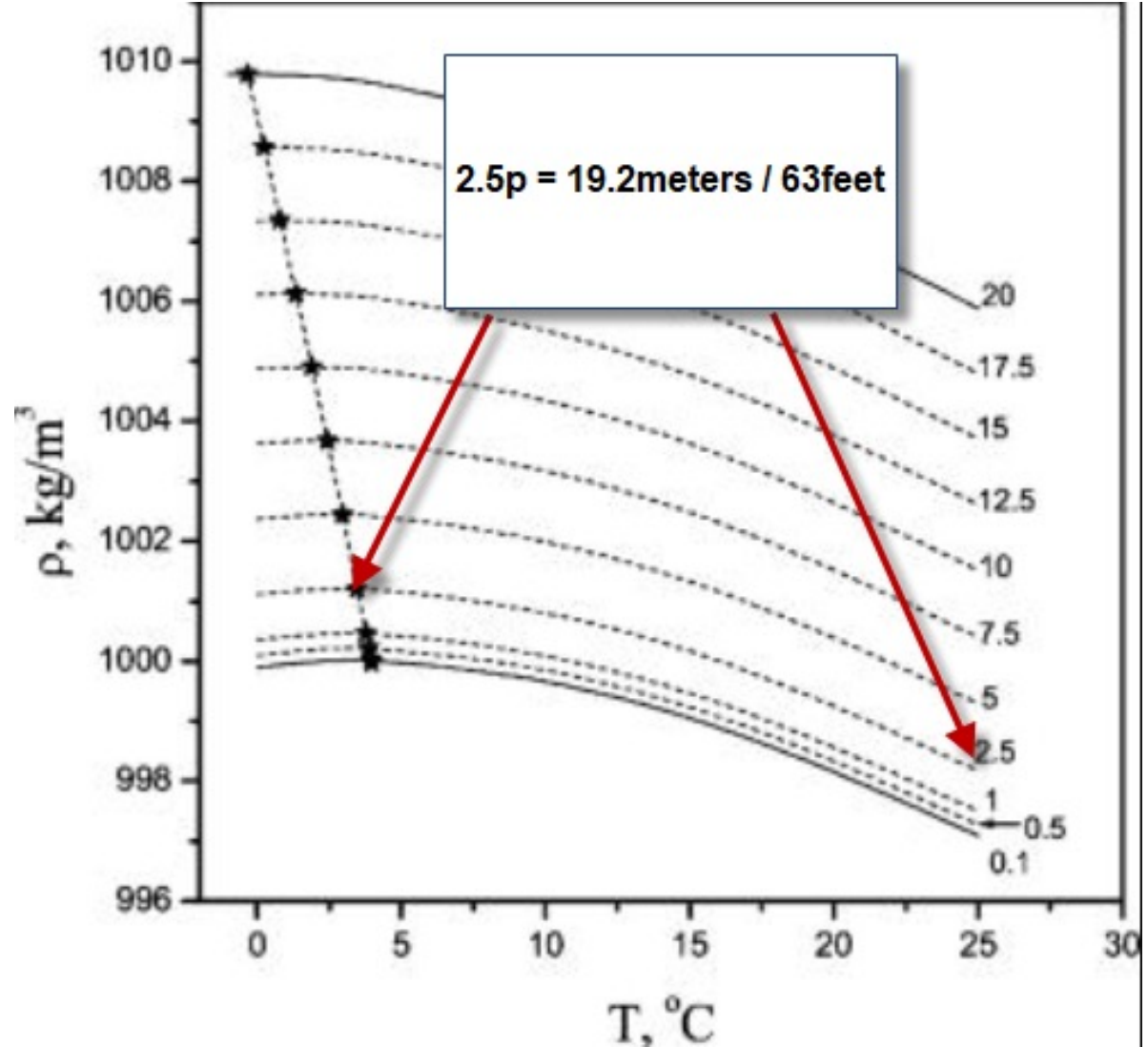

Temperature of Maximum Density

- Temperature of Maximum Density is critical parameter for stratification at low temperatures
- Knowing the exact TMD of your liquid is not critical because:
 - Strategy to manage is not different
 - Our ability to measure the exact temperature of the process liquid when stratification is occurring is limited
- As a guideline beer at 5.8% ABV freezes at -2C or 28.5F
 - Rough guideline is -2C or 3.5F difference compared to water for 5.8% ABV
 - If this relationship holds true, then the TMD of 5.8% ABV would be approximately **2C or 35.7F**



Tank Cooling Dynamics

- Typically tank cooling occurs passively with refrigerant in a cooling jacket
 - Most common glycol
 - Less common ammonia
 - The coolant transmits cold into the tank and there is a temperature layer in contact with the jacket that is colder than the contents of the tank being read by the RTD/thermocouple
 - This phenomenon means it is difficult to see temperature stratification (but not impossible!)
 - As this cold region against the jacket becomes lower in temperature than the TMD the jacket interface liquid rises collecting in the top of the vessel



Challenges in Measuring Tank Temperatures

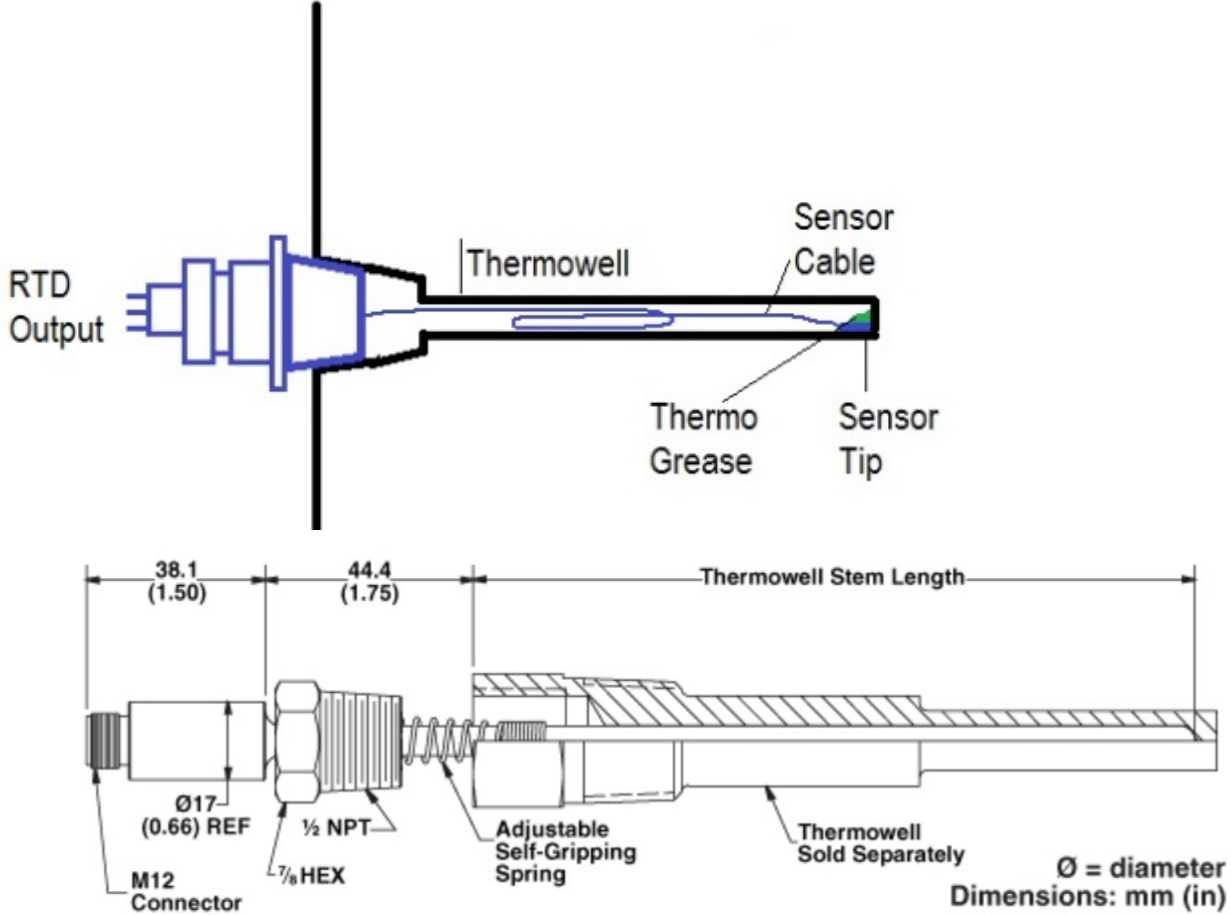
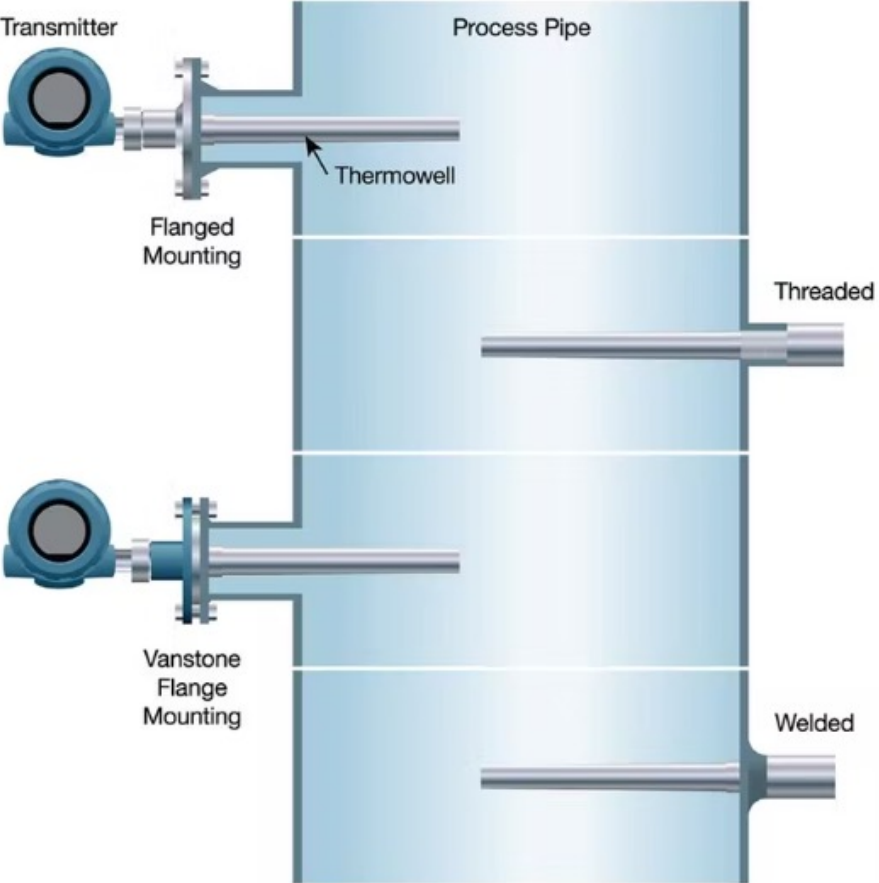

Challenges in Measuring Tank Temperatures

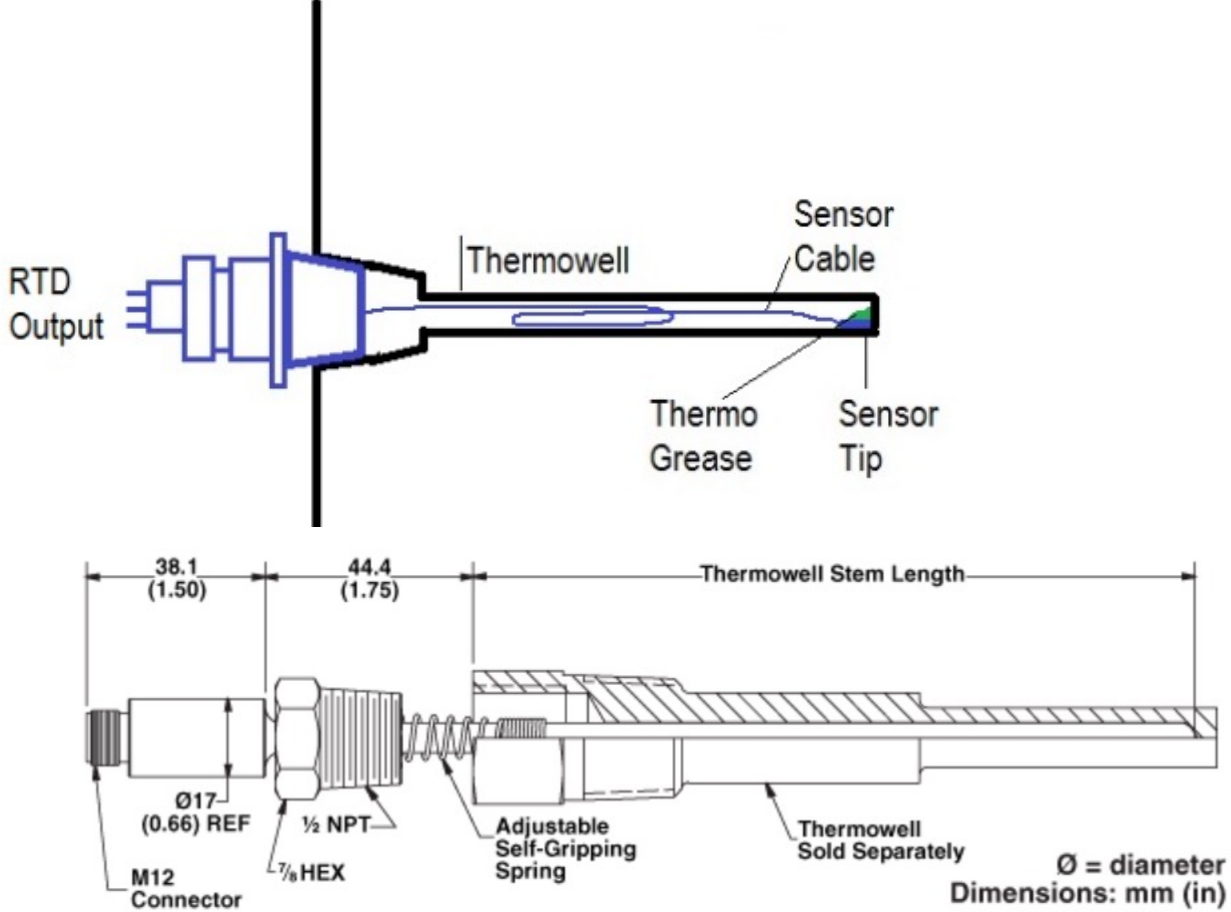
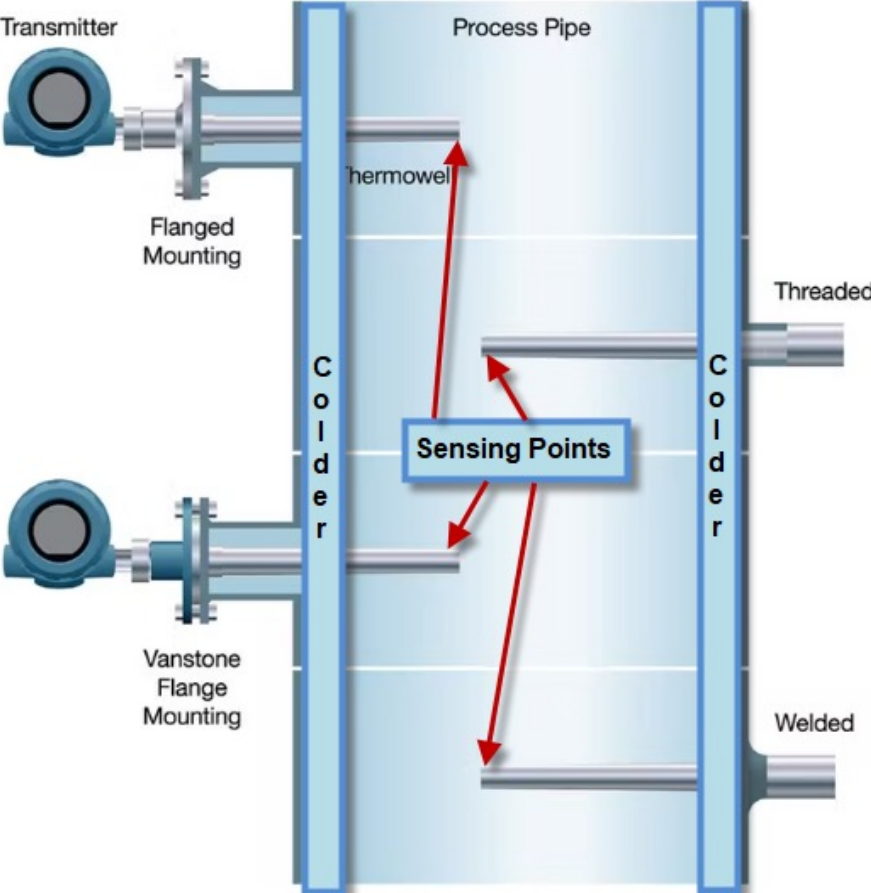

Factors That Promote Temperature Stratification

- Lack of fermentation
 - Even very slight CO₂ evolution can interrupt temperature stratifications
 - Bright tanks are more prone than fermentors
 - Fermentors can still be a significant issue
- High coolant flow or colder coolant
 - The greater the rate of coolant application the greater the temperature differential on the vessel wall and the sooner we will reach and move beyond TMD
- Long storage times
 - Longer the storage times then stratification can build
- Aggressive cooling rates
 - No faster than 1C/hr (~1.8F/hr) but case by case considerations for slower
- Lower Jacket surface area to volume ratio
 - Lower jacket surface area will require higher coolant flow rates and/or lower coolant temperatures to achieve the same cooling duty
 - More aggressive cooling can create larger localized temperature differentials and beer that drops well below TMD
 - Larger unitank cooling jacket guidance ~0.022m²/hl or 0.25 ft²/bbl



Factors That Promote Temperature Stratification (Cont.)

- Vessels with a high height to diameter ratio (greater than 2.7 H:D)
 - Tall vessels compared to width can have an additive effect to cooling impact of liquid
 - As liquid starts rising (at TMD) on lowest jacket the velocity starts to increase
 - The increasing rising velocity allows for more efficient extraction of cooling from the jackets above the lower ones due to turbulent flow
 - This increased efficiency can lead to lower temperatures (relative to body of tank) and lower density
 - This is one of the reasons the top of the tank can become much cooler than the bottom even with the upper jacket not being cooled



Factors That Promote Temperature Stratification (Cont.)

Temperatures $>$
TMD



Temperatures $<$
TMD



Factors That Promote Temperature Stratification (Cont.)

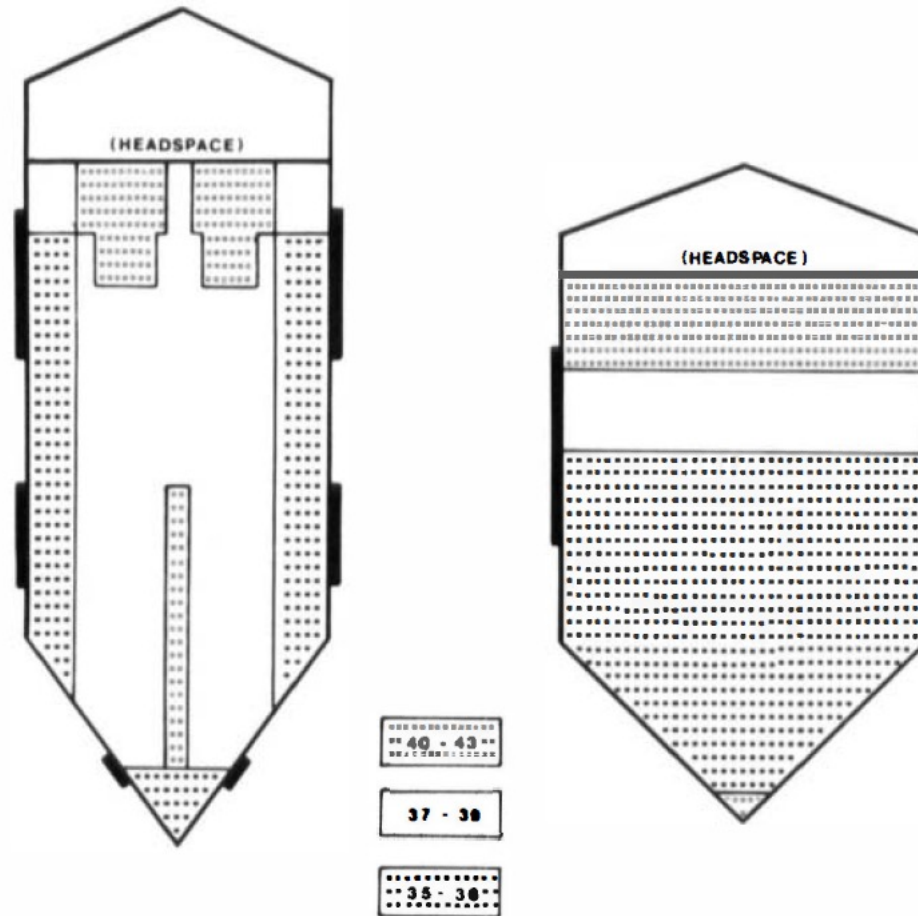

Figure 5. Effect of tank geometry on temperature profiles (°F) during cooling.



Factors That Promote Temperature Stratification (Cont.)

- Discrete cooling valves (on/off only)
 - Discrete valves apply maximum flow rate when actuated which can lead to greater delta in temperature and liquid that reduces below TMD
 - Analog valves (0-100%) that are operating like a discrete valve can be a problem also
- Glycol systems not built to the principal of FILO (First in Last Out)
 - Important to build balanced glycol system where all vessels and jackets will receive an equal amount of flow in a system
 - If system is built FIFO (First in First Out) or FUBAR (...) then some tanks will get much more flow than others and those tanks can have more stratification
 - Analog control valves can help in these cases but limited improvement potential



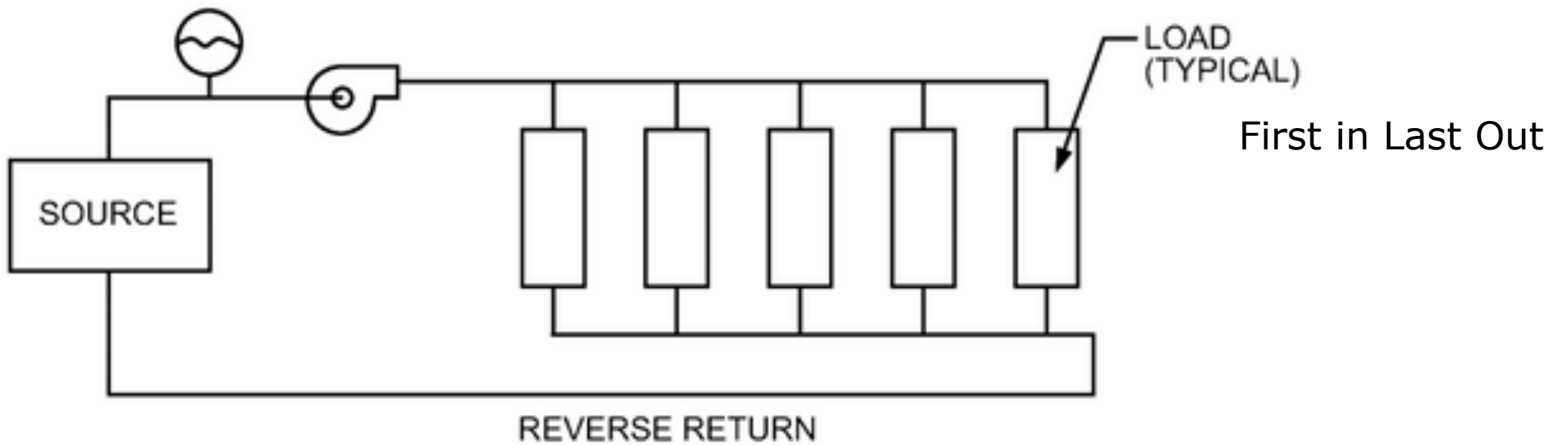
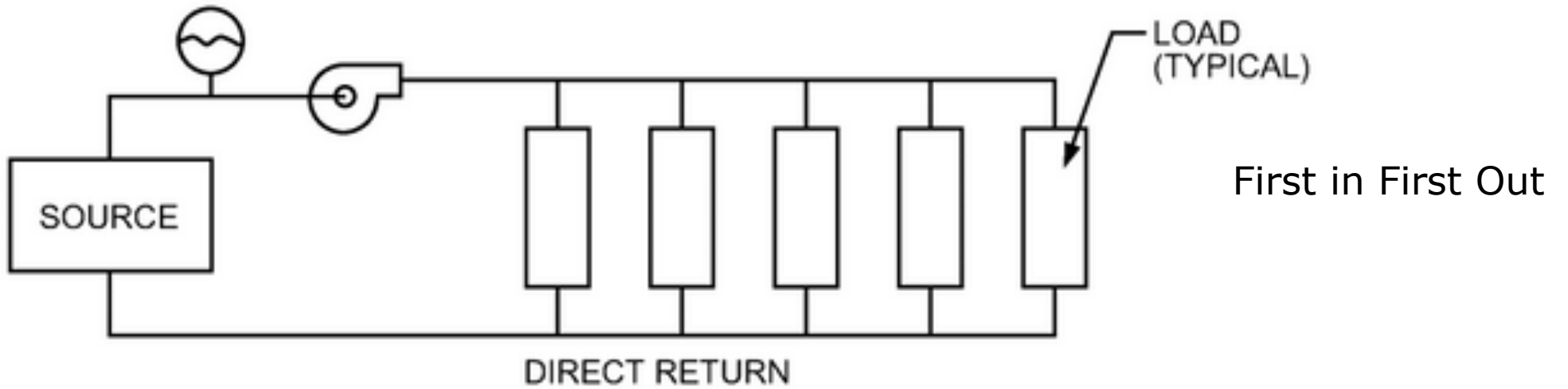

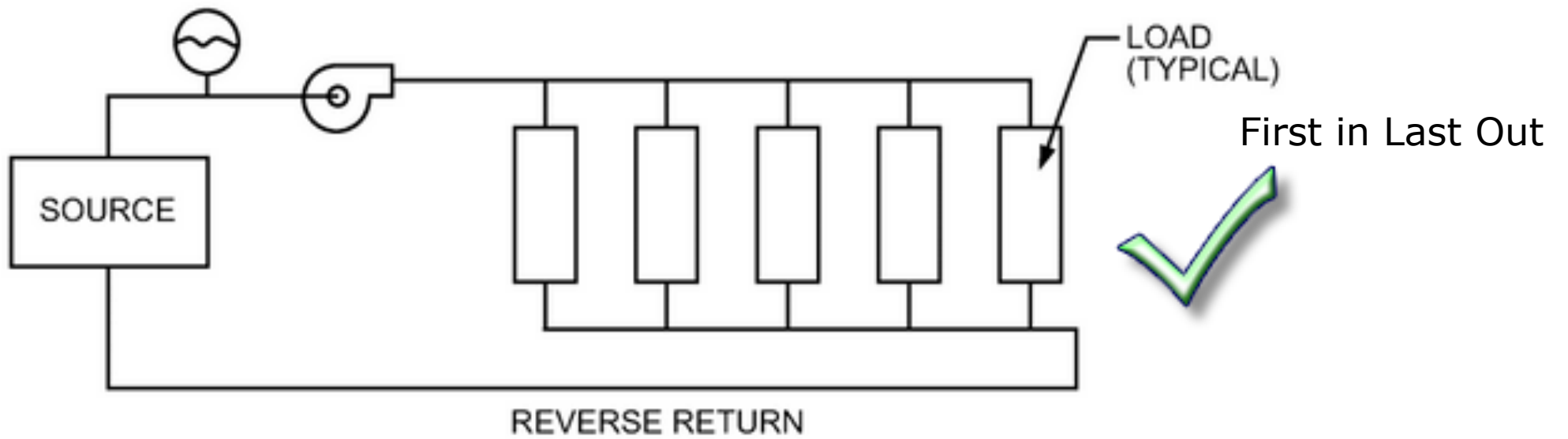
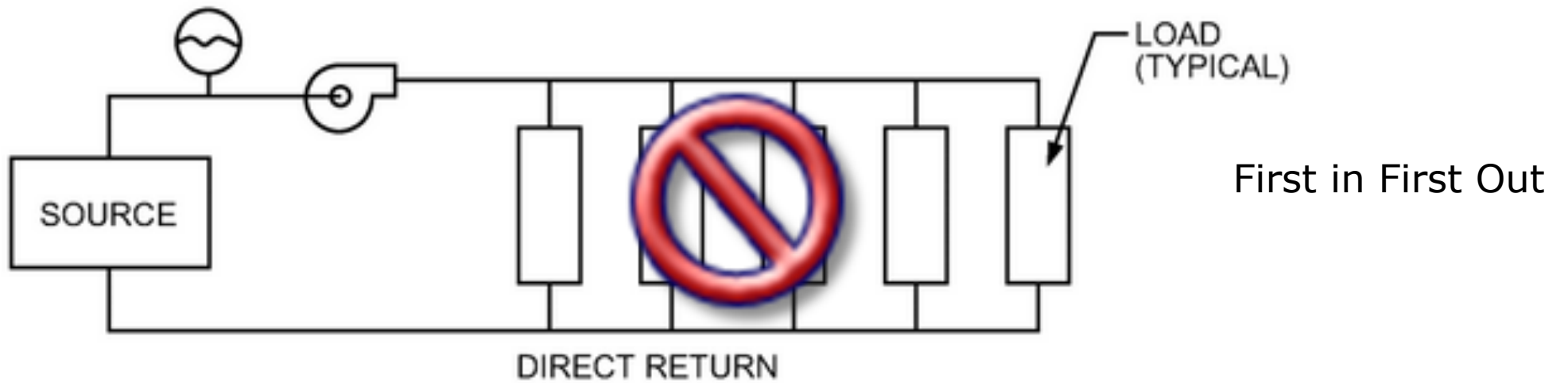

How to Detect Temperature Stratification

- If vessel has multiple sensors then during cold storage you may see lower sensors warming while uppers drop in temperature
- Vessel becoming significantly colder on emptying
 - Upper cold regions move past lower temperature sensors show the degree of stratification
 - The bigger the drop in temperature the greater the issue is
- Ice/slush comes out of tank on empty
 - Extreme cases frozen solids block pumps



How to Avoid Temperature Stratification

- Gentle Cooling
 - Cooling rates 1C/hr (1.8F/hr) maximum and as we approach TMD we may need even slower cooling rates
- Use analog cooling valves or adapt discrete cooling valves to behave like analog (stay tuned...more to come!)
- Use cone cooling
 - Can promote cooling up the center of tank upsetting stratification
 - Significantly less effective if yeast is left in the cone
- Avoid
 - Tall height to diameters
 - Low jacket surface area to volume ratios
 - Cold coolant





How to Work Around Temperature Stratification

- If all else fails, then very gentle CO2 mixing under counterpressure
 - Beware of geyser-ing risk
- Add some sort of mixing device or simple mixing circuit to vessel keeping in mind quality and process risks
- Add a plate heat exchanger on outlet of vessels to correct stratification

How to Improve Cooling performance of discrete valves

- Option 1 (simple)
 - Add an adjustable flow constriction upstream of valve like a ball or gate valve
 - Trial and error to see what manual setting improves performance
 - Solution is not dynamic to other users on system
- Option 2 (moderate difficulty)
 - Operate discrete valves in an analog manner
 - Stay tuned...more to come!
- Option 3 (Most difficult)
 - Convert discrete valves to analog
 - Multiple valve choices including:
 - Best – traditional flow control valve
 - Good – V-ball, diaphragm
 - Fair – butterfly with positioner



Discrete Valves as Analog!

- Concept is if we modulate time on vs. valve position a discrete valve can behave like an analog valve!
 - Set all cooling valves on independent timers that cycle for about 180 seconds
 - Set up degree of error from set point in PLC like the following
 - If process variable (temperature) is 0.2 to 0.4 degrees from setpoint then:
 - Time on 20secs out of 180second cycle
 - If process variable is 0.5 to 0.8 degrees from setpoint then:
 - Time on 40 seconds out of 180 seconds
 - If process variable is greater than 1.0 degrees from setpoint then:
 - Time on 60secs out of 180 seconds
- Approach should allow for gentle cooling and lower the degree that liquid enters temperatures below TMD



In Summary

- Unitanks can be prone to temperature stratification at temperatures close to TMD
- Careful tank design and cooling control can be used to lower issues
- Less is more when fighting temperature stratification
 - Cooling flow
 - Warmer coolant temperatures
- Cone cooling only with little to no yeast present may be an effective tool to offset temperature stratification
- Original tank design can be critical in cooling performance
 - Little to no literature insight for small unitanks



Resources

- Chaplin, M.; “Water and Life: The Unique Properties of H2O”; pp. 75-78
- [researchgate.net/profile/Edgar_Zanotto/publication/7991287/figure/fig5/AS:279285362380808@1443598227359/Density-of-water-vs-temperature-at-different-pressures-in-MPa-as-specified-in-the.png](https://www.researchgate.net/profile/Edgar_Zanotto/publication/7991287/figure/fig5/AS:279285362380808@1443598227359/Density-of-water-vs-temperature-at-different-pressures-in-MPa-as-specified-in-the.png)
- SIMULATION OF FERMENTOR COOLING PERFORMANCE, REUTHER, H., BRANDON, H., RAASCH, J., RAABE, D.; Monatschrift fur Brauwissenschaft, 1995-Oct, Volume: 48 Pages: 310 - 317
- [processingmagazine.com/process-control-automation/instrumentation/article/15587300/when-and-when-not-to-use-thermowells-in-process-temperature-measurement](https://www.processingmagazine.com/process-control-automation/instrumentation/article/15587300/when-and-when-not-to-use-thermowells-in-process-temperature-measurement)
- ASHRAE Handbook: HVAC Systems and Equipment
- CHAPTER 12 HYDRONIC HEATING AND COOLING SYSTEM DESIGN
- Cooling characteristics of uni-tanks, Larson, J.W. and Brandon, H.J., MBAA Technical Quarterly, Vol. 25, pp 4 1-46, 1988
- Design and Operation of Unitanks, Knudsen, F., Vacano, N., Brewers Digest, July 1972



Questions



- Thanks
 - AB-I
 - MBAA-ASBC
 - Enerfab